

Nimbl™ User Guide

Model PD08-N1



nimbl™

PNEUMATIC COMPRESSION SYSTEM

Tactile
MEDICAL®

Table of Contents

Chapter 1 Before You Get Started	1
1.1 How to Contact Tactile Medical	1
1.2 Safety Precautions and Explanation of Symbols	2
1.3 Indications for Use	4
1.4 Contraindications	5
1.5 Unpacking Instructions.....	5
1.6 Garment Labels	6
1.7 Essential Performance	7
1.8 Kylee – Your Personal Lymphedema Assistant Mobile Application.....	7
1.9 Nimbl Firmware Update	9
Chapter 2 The Nimbl System	10
2.1 System Components	10
2.2 Side Panel	11
2.3 Treating the Lower Extremity	12
2.4 Treating the Upper Extremity	13
Chapter 3 Controller Unit Set Up	14
3.1 Setting Up the Controller Unit	14
3.2 Connecting Your Bilateral Adapter	15
3.3 Connecting Your Hose(s) to the Controller Unit	16
3.4 Connecting the Optional Connector Extension	18
Chapter 4 Garment Application	20
4.1 Applying the Full Leg Garment	21
4.2 Applying the Arm Garment.....	23
Chapter 5 Conducting a Treatment Session	25
5.1 Selecting Your Pressure Setting	25
5.2 Starting the Treatment Session	26
5.3 Pausing the Treatment Session	26
5.4 Completing the Treatment Session.....	27
5.5 Disconnecting the Hose from the Controller Unit	27
5.6 Storing the Nimbl System	29
5.7 Cleaning the Nimbl System	29
5.8 Disinfecting the Nimbl System.....	30
Chapter 6 Troubleshooting and Specifications	31
Chapter 7 Warranty	37
7.1 Limited Warranty and Service for Home Use.....	37
7.2 Limited Warranty and Service for Facility Use.....	38
7.3 Return Policy	38
7.4 Equipment Lifetime	38
Chapter 8 Cybersecurity Introduction	39
8.1 Security of Data.....	39
8.2 Confidentiality	40
8.3 Availability.....	41
8.4 Authentication and Authorization	41
8.5 Accountability	42
8.6 Summary.....	42
Chapter 9 FCC Compliance	43
Chapter 10 Technical Information	44
10.1 Technical Information	44
10.2 Device Labels	48
For Additional Questions	Back Cover

Before You Get Started

Read the entire guide before attempting to connect or operate this product. Keep this guide for future reference.

The Nimbl system is a pneumatic compression device designed for at-home treatment of lymphedema, chronic edema, venous insufficiency, and wound healing. When used daily, pneumatic compression can help you manage your condition, improve your health, and allow you to enjoy a better quality of life.

This guide provides the information to help you set up and use your Nimbl system.

1.1 How to Contact Tactile Medical









If you have questions about the Nimbl system or require service, contact us one of these ways:

- **Text or Call:** 612.355.5100
- **Toll Free Phone:** 833.3TACTILE (833.382.2845)
- **Email:** customerservice@tactilemedical.com
- **Customer Care Hours:** 7 a.m. to 7 p.m. CT, Monday–Friday

If you have medical questions, please contact your physician or healthcare provider.

1.2 Safety Precautions and Explanation of Symbols

The Nimbl system symbols adhere to the ISO15223-1 2021 International Standard.

	<p>IMPORTANT: Read Instructions Before Using Before attempting to connect or operate this product, please read the entire guide. Keep this guide available for future reference.</p>
	<p>CAUTION</p>
	<p>Manufacturer's Model ID</p>
Rx Only	<p> CAUTION: U.S. Federal law restricts this device to sale by, or on the order of, a licensed healthcare professional. Consult your physician or other healthcare provider for recommendations regarding your treatment program, treatment cycles, and/or duration of treatment. Use this product only at the settings prescribed by your healthcare provider.</p>
	<p>Do NOT Dispose with General Household Waste Tactile Medical complies with the Waste Electric and Electronic Equipment Directive (WEEE) 2002/96/EC. Contact Tactile Medical toll free at 833.3TACTILE (833.382.2845) from 7 a.m. to 7 p.m. CT, Monday–Friday to get disposal instructions.</p>
	<p>Type BF Applied Part</p>
	<p>Device Serial Number</p>
	<p>TUV SUD Mark Product Category: Medical Equipment Product Category CCN: PIDF Class II with respect to electrical shock, fire, and mechanical hazards only in accordance with EN60601-1</p>
IP22	<p>The Nimbl system complies with IEC60329 regarding the degree of protection against water and particulates.</p>

EMC Precautions

The Nimbl system is Medical Electrical Equipment that has been tested and demonstrated to be compatible with electromagnetic compatibility (EMC) CISPR 11 Class B limits and is therefore suitable for use in hospital, clinic, and home care environments.

WARNING: Do not use device in the Emergency Medical Service (EMS) environment.

WARNING: The Nimbl provides a sequential inflation and deflation of the garment chambers in a defined sequence. An EM disturbance may cause the controller to stop functioning. Use of this equipment adjacent to or stacked with other equipment should be avoided because it could result in improper operation. If such use is necessary, this equipment and the other equipment should be observed to verify that they are operating normally.

WARNING: Power cords can be affected by EMC. Use only the power cord provided by Tactile Medical. Unauthorized power adapters could result in increased electromagnetic emissions or decreased electromagnetic immunity of this equipment and result in improper operation.

Portable RF communications equipment (including peripherals such as antenna cables and external antennas) should be used no closer than 30 cm (12 inches) to any part of the Nimbl system. If the caution isn't observed, degradation of the performance of the device could occur.

WARNING: Do not interface with or plug anything into the serial port found under the bumpers on the controller.

WARNING: Risk of Electric Shock

- Do not attempt to service the controller unit and accessories. Such attempts could result in injury or damage to the product, and will void any warranty.
- Do not disassemble the controller unit.
- Unplug the controller unit when not in use.
- The Nimbl system is to be used indoors only.
- Do not use the controller unit near water or while bathing.
- Do not reach for the controller unit if it falls into water. Unplug the controller unit at the electrical outlet immediately.
- Do not use the garment if it is wet.

WARNING: Risk of Personal Injury

- Use the controller unit only for its intended purpose, as directed in this guide.
- Use only the power adapter provided with your Nimbl system.
- Use only accessories approved by Tactile Medical. Other accessories may damage the system or interfere with system function.
- Set up the controller unit in a manner that provides easy access to the power adapter should it become necessary to unplug quickly.
- Never operate the controller unit if the power adapter or plug is not working properly, if it has been damaged, or if the controller unit has been dropped into water. Return it to Tactile Medical for inspection and/or replacement. Do not modify the power adapter or plug.

WARNING: Risk of Personal Injury (continued)

- Keep the power adapter away from heated surfaces.
- Never operate the controller unit where the power adapter or tubing harness will present strangulation or tripping hazard.
- Strangulation potential: Power adapter and tubing bundle should never be placed near or around a person's neck.
- Do not use the Nimbl system in the presence of flammable gasses, including flammable anesthetics.
- Do not operate the device while smoking.
- Caution garment temperatures may exceed 41°C or 106°F.

CAUTION: Risk of Device Damage

- Never block the ventilation openings on the sides of the controller unit. Keep the ventilation openings free of debris such as lint and hair.
- Never operate the controller unit on a soft surface, such as a bed, sofa or pillow where the ventilation openings may be blocked.
- Never drop or insert any object into any opening of the controller unit.
- Never use sharp objects, such as pins, scissors or clasps on or near the Nimbl system.
- Never use hot devices such as irons or blow dryers on or near the Nimbl system.
- Keep the product free from debris to avoid valve closed or valve opened failures.
- Never place the product in a position or location that would allow the tubing harness to become pinched.



1.3 Indications for Use

The Nimbl system is intended for use by medical professionals and patients who are under medical supervision for the treatment of the following conditions:

- Chronic edema
- Lymphedema
- Venous insufficiency
- Wound healing

1.4 Contraindications

The Nimbl system should not be used if you have one or more of the following conditions:

- Heart failure (acute pulmonary edema, decompensated acute heart failure)
- Acute venous disease (acute thrombophlebitis, acute deep venous thrombosis, acute pulmonary embolism)
- Severe peripheral artery disease (critical limb ischemia including ischemic rest pain, arterial wounds, or gangrene)
- Active skin or limb infection/inflammatory disease (acute cellulitis, other uncontrolled skin or untreated inflammatory skin disease)
- Active cancer (cancer that is currently under treatment, but not yet in remission)
- Any circumstance where increased lymphatic or venous return is undesirable

1.5 Unpacking Instructions

When your Nimbl system arrives, it is important that you carefully unpack the contents and ensure that you have all the equipment required to begin operation. If the Nimbl system is exposed to storage temperature extremes, allow the system to stabilize at room temperature for at least six hours before use.

Included in the box, you should find the following:

- Controller unit
- Garment(s) and accessory(ies) to treat your condition
- Power adapter
- Quick start guide
- Bilateral adapter (if prescribed bilateral treatment)

The garment(s) and accessory(ies) you receive will depend upon your individual treatment requirements. If you are missing any of the items listed for your prescribed treatment, please text or call Customer Care at 612.355.5100.

In addition to the accessories included with your Nimbl system, these non-prescription accessories may be purchased separately at **shop.tactilemedical.com**:

- Travel bag
- Rechargeable battery (separate user guide)

Lower Extremity Treatment

The garment(s) and device accessory(ies) needed for lower extremity treatment may include the following:

- Full leg garment(s)
- Extender (provided only if ordered)
- Connector (provided only if ordered)

Upper Extremity Treatment

The garment(s) and device accessory(ies) needed for upper extremity treatment may include the following:

- Arm garment(s)

1.6 Garment Labels

The label is located on the garment or accessory. It indicates the body area the garment or accessory is to be applied (leg or arm) (**Figure 1.6.a.**).

Figure 1.6.a. Label Examples

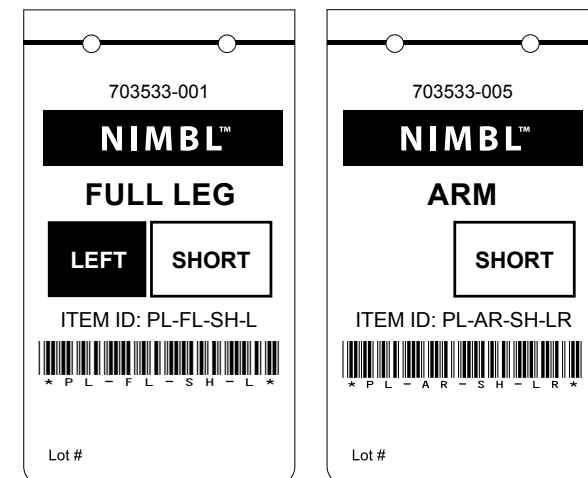

1.7 Essential Performance

This device is designed for inflation and deflation of the garment chambers in a defined sequence and it has passed required testing to meet those requirements. If electromagnetic (EM) disturbances impact the device's performance, it will generate errors as described in **Table 2** on page 35.

1.8 Kylee – Your Personal Lymphedema Assistant Mobile Application

Kylee is a free mobile app provided by Tactile Medical. With Kylee, you can keep a record of your symptoms and at-home treatment sessions to help you track your therapy and progress. The app captures data by connecting your Nimbl system to your mobile device through wireless Bluetooth® technology. Data is transmitted when your Nimbl device is on, the Kylee application is open, and your mobile device is within Bluetooth® range (33 ft.). The mobile device must have support for Bluetooth® 4.1 or later for connectivity to the Nimbl device.

Kylee captures treatment and symptom information into an Activity Report that can be shared with your healthcare provider for insight into how your treatment is working.

Learn more at www.tactilemedical.com/kylee.



Connecting Your Nimbl Controller Unit to Kylee

To connect your Nimbl device to Kylee follow these steps:

1. Download Kylee from the Apple App Store, Google Play Store, or use your smartphone to scan the QR code above.
2. Create an account in Kylee.
3. Ensure you have the Bluetooth® setting for your mobile device turned on.
4. Follow the step-by-step guide within Kylee to connect your Nimbl device to Kylee via Bluetooth®.

NOTE: The serial number is located on the side of your controller unit in the middle of the label, as shown in the example below. It can be scanned into Kylee by using the QR code or manually entered.

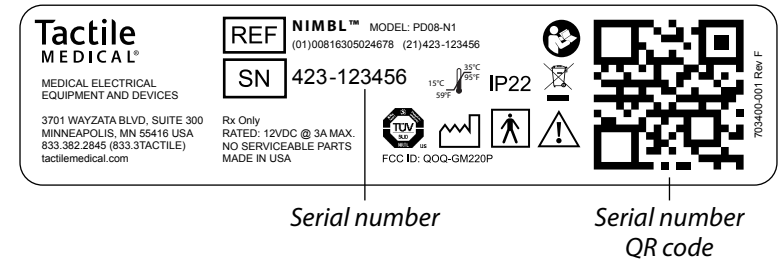

Nimbl Bluetooth® Status

The Bluetooth® status is located next to the Bluetooth® button on the side of the controller.

When Bluetooth® pairing is successful, the LED will illuminate blue.

When Bluetooth® isn't paired with a mobile device, the LED will not illuminate.

When the pairing process is initiated, the LED will flash quickly.

When data is being shared between the Nimbl device and Kylee, the LED will flash slowly.

1.9 Nimbl Firmware Update

The Nimbl controller unit firmware can be updated over the Bluetooth® wireless connection with the Kylee application.

Firmware updates to the controller may be used to provide updated functionality or address potential issues with the Nimbl system.

To update the controller unit, first follow the steps in **Section 1.8 Connecting Your Nimbl Controller Unit to Kylee** on page 7. Once connected to Kylee, you may see in a few different places that an update is available:

- On your mobile device's operating system
- On the Kylee Home Screen via a link
- On the Kylee My Device screen via an Update Firmware button

If a firmware update is available, the **Update Firmware** button will be displayed on the My Device screen in Kylee. The firmware update process cannot be started during a therapy session and a session cannot be started while the firmware update is underway. Your mobile device should have at least 50% battery power before beginning the update, which will take up to one minute to complete. Power to the Nimbl controller unit must not be interrupted during the update process.

After selecting the **Update Firmware**, a prompt is displayed with the details of the contents of the update and the firmware update process. Once selected, the Kylee application will transfer the firmware update to the controller unit and the Kylee app will inform you if successful. The controller unit will then confirm the update has been received and will reboot with the new version.

The Nimbl System

The Nimbl system is a pneumatic compression device that delivers intermittent sequential compression treatment to the affected extremities of patients with lymphedema, chronic edema, venous insufficiency, and wound healing.

NOTE: *No special skills, training or knowledge is required to operate the Nimbl system.*

2.1 System Components

The Nimbl system consists of two primary components:

Controller Unit

The controller unit delivers compressed air via a hose connector which is attached to the garment. Your clinician may prescribe an additional garment for simultaneous bilateral treatment. The device applies different levels of pressure along the length of your limb. For example, your toes or fingers will receive more pressure; your thigh or upper arm will receive less.

Garment

The air-chambered garments are made of soft, pliable nylon and polyester fabric. They are designed to fit around the limb(s) and fasten with zippers.

The lower extremity garment(s) are used to treat the leg. Depending on your clinical needs and size, you may be prescribed a short or long leg garment (with corresponding extender).

The upper extremity garment(s) are used to treat the arm. Depending on your clinical needs and size, you may be prescribed a short or long arm garment.

NOTE: *Both Nimbl labeled garments can be used with your Nimbl controller.*

2.2 Side Panel

The Nimbl controller unit has three buttons as shown in **Figure 2.2.a.** Your healthcare provider will determine what pressure setting is appropriate for you. The Bluetooth® button indicates a connected device.

NOTE: Please consult with your healthcare provider before changing pressure settings.

Figure 2.2.a. Side Panel



2.3 Treating the Lower Extremity

Full Leg Treatment

This option provides full leg treatment upward from the foot towards the thigh through the sequential inflation of the eight chambers.

Treatment time: 60 minutes.

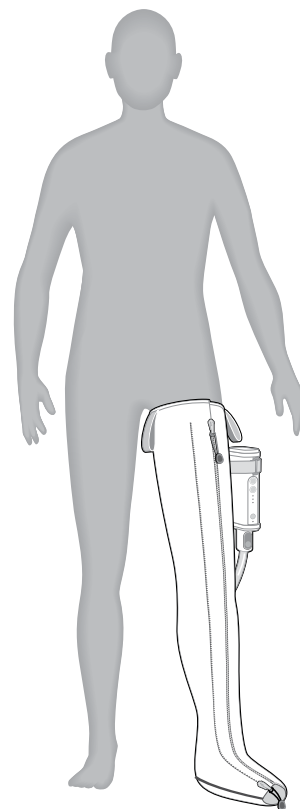

Figure 2.3.a. Full Leg

Directs fluid from toes to top of thigh in one continuous motion.

2.4 Treating the Upper Extremity

Arm Treatment

This option provides full arm treatment upward from the hand towards the shoulder through the sequential inflation of the eight chambers.

Treatment time: 60 minutes.

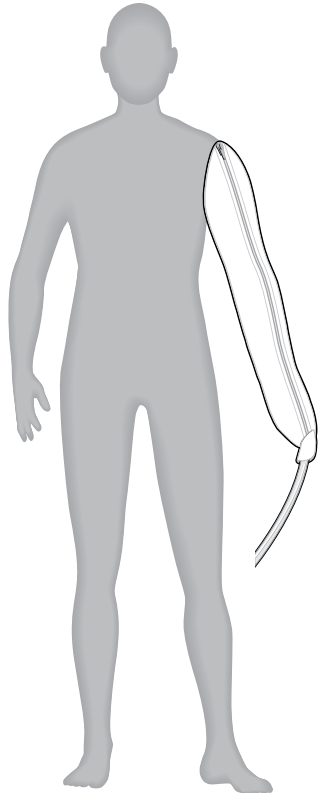

Figure 2.4.a. Arm
Begins at fingertips and ends at top of biceps in one continuous motion.

Controller Unit Set Up

In this chapter you will learn how to set up the controller unit and select the proper settings prior to receiving treatment.

3.1 Setting Up the Controller Unit

Follow the steps below:

1. Find an appropriate location for a treatment session (e.g., sofa, bed). Place the controller unit on a sturdy, flat surface near an electrical outlet. Position the device so you have easy access to the plug.
2. Plug the supplied power adapter into the power adapter inlet on the controller unit. Then, plug the two-pronged power adapter into an electrical outlet (**Figure 3.1.a.**).

Figure 3.1.a. Power Adapter

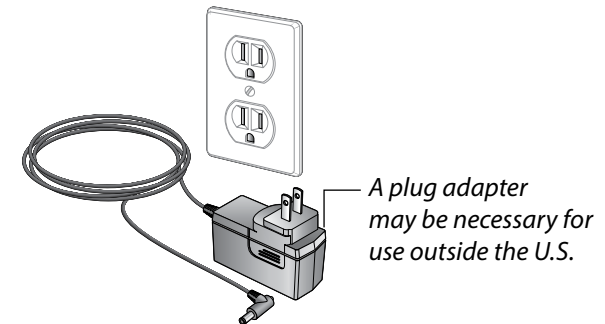

3.2 Connecting Your Bilateral Adapter

If you are conducting bilateral treatment, you will have received a bilateral adapter that connects to the controller unit (**Figure 3.2.a.**). The adapter must be connected to the controller unit prior to connecting your garments. To connect the adapter:

1. Align the single and double keys on the adapter to the corresponding position on the controller (**Figure 3.2.b.**).
2. Push the adapter forward; it will hook on both sides of the controller unit port. You should hear a click when each of the latches is properly connected. You will hear two clicks, one for each button (**Figure 3.2.c.**).

Figure 3.2.a. Bilateral Adapter

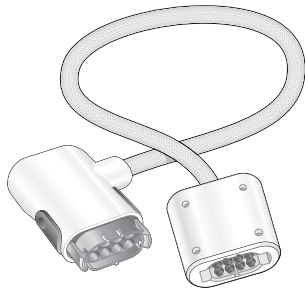
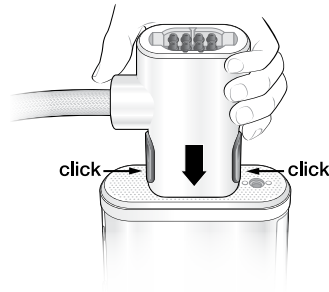

Figure 3.2.b. Connecting the Bilateral Adapter to the Controller Unit



Figure 3.2.c. Properly Connecting the Latches



3.3 Connecting Your Hose(s) to the Controller Unit

Follow the steps below to attach the hose to the controller unit:

1. Attach the power cord to the controller and set within reach for later.
2. Put on the garment.
3. Hold the hose connector by the white enclosure and align the single and double keys on the connector to the corresponding position on the controller (**Figure 3.3.a.**).

Figure 3.3.a. Connecting the Hose to the Controller Unit



4. Push the connector forward; it will hook on both sides of the controller unit port. You should hear a click when each of the latches is properly connected. You will hear two clicks, one for each button (**Figure 3.3.b.**).

Figure 3.3.b. Properly Connecting the Latches

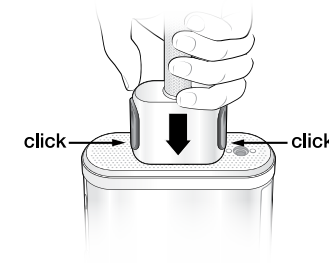

5. If you are conducting bilateral treatment, connect one hose to the port directly on the bilateral adapter (**Figure 3.3.c.**) and the remaining hose connects to the latch on the end of the bilateral adapter hose (**Figure 3.3.d.**).

Figure 3.3.c. Connecting the Hose to the Bilateral Adapter

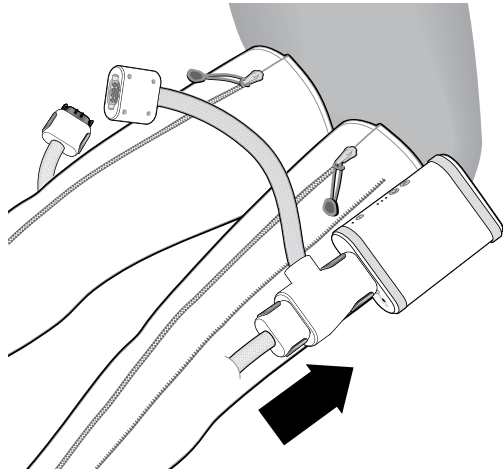
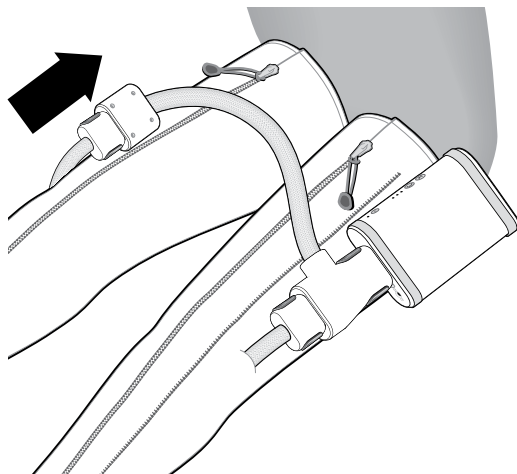

Figure 3.3.d. Connecting the Garment Hose to the Bilateral Adapter Hose



3.4 Connecting the Optional Connector Extension

Follow the steps below if you have the optional connector extension:

1. Place the controller on the table and attach the power cord.
2. Put on the garment.
3. Hold the connector extension (side with blue buttons) by the white enclosure and align the single and double keys on the connector to the corresponding position on the controller (**Figure 3.4.a.**).

Figure 3.4.a. Connecting the Connector Extension to the Controller Unit

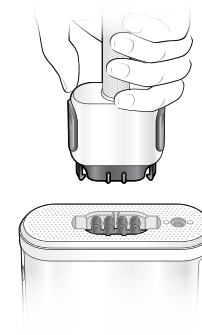

4. Push the connector forward; it will hook on both sides of the controller unit port. You should hear a click when each of the latches is properly connected. Two clicks will be heard, one for each button (**Figure 3.4.b.**).

Figure 3.4.b. Properly Connecting the Latches

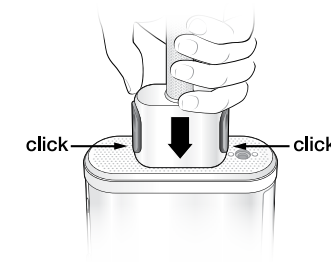

Garment Application

5. Repeat this step to connect the garment to the connector extension (**Figure 3.4.c. and Figure 3.4.d.**).

Figure 3.4.c. Connecting the Connector Extension to the Garment

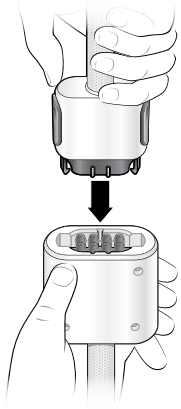
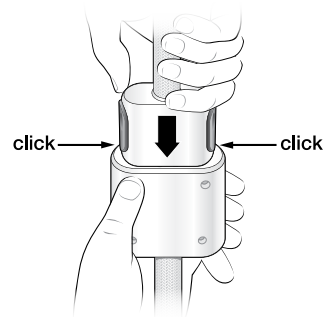
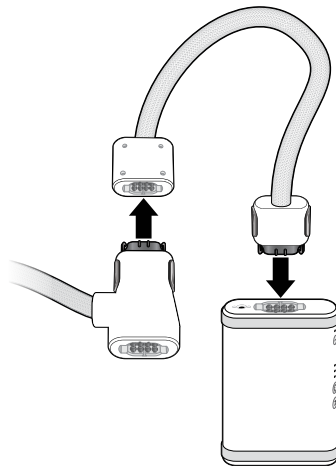

Figure 3.4.d. Properly Connecting the Latches



6. If conducting bilateral treatment, connect the end of the connector extension to the bilateral adapter by aligning the single and double keys on the adapter to the corresponding key positions on the connector. Push the adapter forward; you will hear two clicks indicating that you made a proper connection (**Figure 3.4.e.**).

Figure 3.4.e. Using the Connector Extension with the Bilateral Adapter



Prior to starting treatment it is important to:

1. Be sure you have the recommended garment to complete your treatment.
2. Choose a time that will limit interruptions requiring you to pause treatment. The treatment session lasts 60 minutes.

CAUTION

To avoid skin irritation that may result from contact with the polyester material, wear lightweight, loose-fitting (non-elastic) cotton clothing (example: scrubs, stockinette). If skin irritation develops, consult with your doctor.



Lymph fluid is moved through the vessels in the skin. It is important to avoid wearing anything during treatment that may hamper the lymph flow. These items include:

- **Belts**
- **Jewelry**
- **Restrictive clothing such as:** elastic-banded underwear, compression bandaging, elastic-banded socks, compression garments, bra

CAUTION



The Nimbl garment should not be placed in direct contact with an open wound. It is recommended that wounds be properly dressed before the garment is applied. Contact your healthcare provider if you have any questions.

4.1 Applying the Full Leg Garment

Garment Preparation:

1. Once the garment is connected to the controller unit, unfold and place the full leg on the bed or sofa with the inside garment material (darker fabric) facing up.
2. Apply your garment using the zipper configuration indicated on your prescribed treatment plan. Zip the appropriate pull string color (teal or black) to the numbered zipper (#1 or #2). Use the colored zipper to start the zipper. The following zipper configurations are available:
 - Black pull string to zipper #1 – Petite
 - Black pull string to zipper #2 – Small
 - Teal pull string to zipper #1 – Medium
 - Teal pull string to zipper #2 – Large

NOTE: If you are using an extender, position it so the narrow side is located at the foot of the leg garment. Connect the teal pull string located on the leg garment to the zipper on the extender. Then, connect the teal pull string located on the extender to the #2 zipper on the leg garment.

3. Zip the garment up half way.

Garment Application:

4. Sit down and slide your leg into the garment (see **Figure 4.1.a.**). Pull the garment up to the top of your thigh; your foot should not exit the front of the garment. Zip the garment up completely and ensure the zipper pull is flat against the base to lock the zipper in place.

NOTE: If the suggested configuration is too tight or too loose, try another configuration based on the listings above.

Figure 4.1.a. Applying the Full Leg Garment

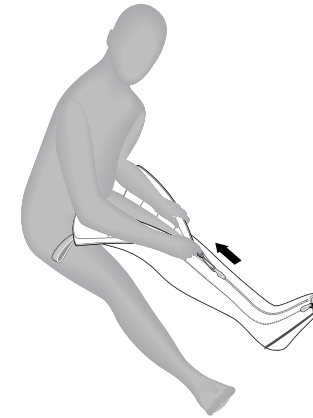

5. Finally, place a pillow under your calf and foot to elevate your leg slightly above your hips for optimal treatment (**Figure 4.1.b.**).

Figure 4.1.b. Fully Applied Full Leg Garment

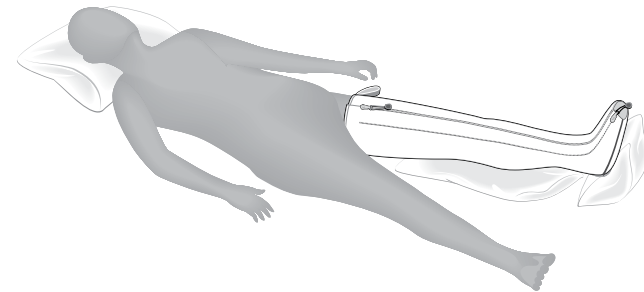

4.2 Applying the Arm Garment

Garment Preparation:

1. Once the garment is connected to the controller unit, unfold and place the arm garment on the bed or sofa with the zipper facing up.
2. Apply your garment using the zipper configuration indicated on your prescribed treatment plan. Zip the appropriate pull string color (teal or black) to the numbered zipper (#1 or #2). Use the colored zipper to start the zipper. The following zipper configurations are available:
 - Black pull string to zipper #1 – Petite
 - Black pull string to zipper #2 – Small
 - Teal pull string to zipper #1 – Medium
 - Teal pull string to zipper #2 – Large
3. Zip the garment up completely and ensure the zipper pull is flat against the base to lock the zipper in place.

Garment Application:

4. Slide your arm into the garment.

NOTE: *If the suggested configuration is too tight or too loose, try another configuration based on the listings above.*

5. Pull the arm garment up over your shoulder making sure your fingertips remain fully enclosed in the garment. The zipper should align with the top of your shoulder.

Figure 4.2.a.
Preparing the
Arm Garment

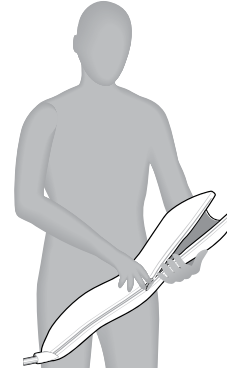

Figure 4.2.b.
Slide the
Arm Garment On

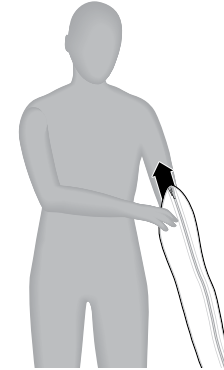
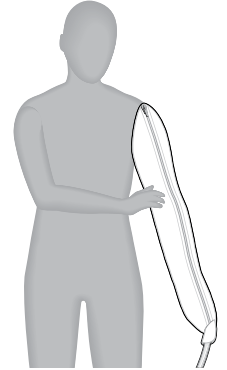

Figure 4.2.c.
Fully Applied
Arm Garment



Conducting a Treatment Session

Once you have connected your garment to the controller unit and applied the garment to your limb, you are ready for your treatment session with the Nimbl system. Start your treatment session using the instructions below.

5.1 Selecting Your Pressure Setting

Follow the steps below to select the settings prescribed by your healthcare provider:

NOTE: The controller unit will recall the pressure setting used during the last treatment session. In most situations the pressure settings will not need to be modified from one treatment to the next. The controller unit is on when plugged in.

Select the pressure setting prescribed by your physician.

The  button allows you to toggle between the three pressure levels: low, medium, and high. Select the prescribed pressure setting listed on your prescribed treatment plan.

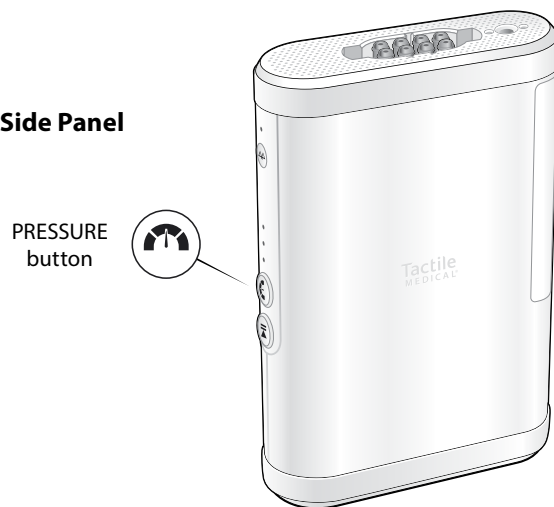





Figure 5.1.a. Side Panel

5.2 Starting the Treatment Session

1. Prepare yourself for an uninterrupted session.
2. Use a pillow to elevate your affected limb(s) slightly above your torso during treatment and angle your limb(s) about 45 degrees out from the side of your body.
3. When properly positioned, press the  button on the controller unit to begin treatment.
4. For best results, relax and take deep abdominal breaths during treatment.

5.3 Pausing the Treatment Session

You may pause treatment for up to 15 minutes at any point during a session by pressing the  button. To resume your treatment, press the  button.

NOTE: After 15 minutes, the controller will turn off. When you turn the controller back on, it will initiate a full hour session.

5.4 Completing the Treatment Session

Nimbl will automatically stop and the garment will deflate once the treatment is complete. Do not turn off or disconnect the garment during this deflation process.

CAUTION

If an electrical power outage or power interruption occurs during a treatment session, the garment may remain inflated.



To remove the garment from your extremity, it may be necessary to disconnect the hose connector from the controller unit to allow release of the trapped air.

5.5 Disconnecting the Hose from the Controller Unit

To disconnect after treatment, press both blue buttons to disengage the connector and pull connector backwards (Figure 5.5.a.).

Figure 5.5.a. Disconnecting the Connector from the Controller

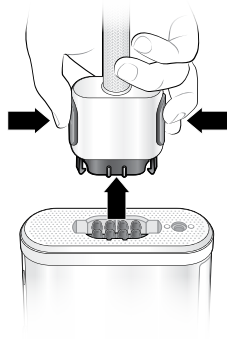

If conducting bilateral treatment, repeat the step to disconnect the bilateral adapter (Figure 5.5.b.) and optional connector extension (Figure 5.5.c.).

Figure 5.5.b. Removing the Connector from the Bilateral Adapter

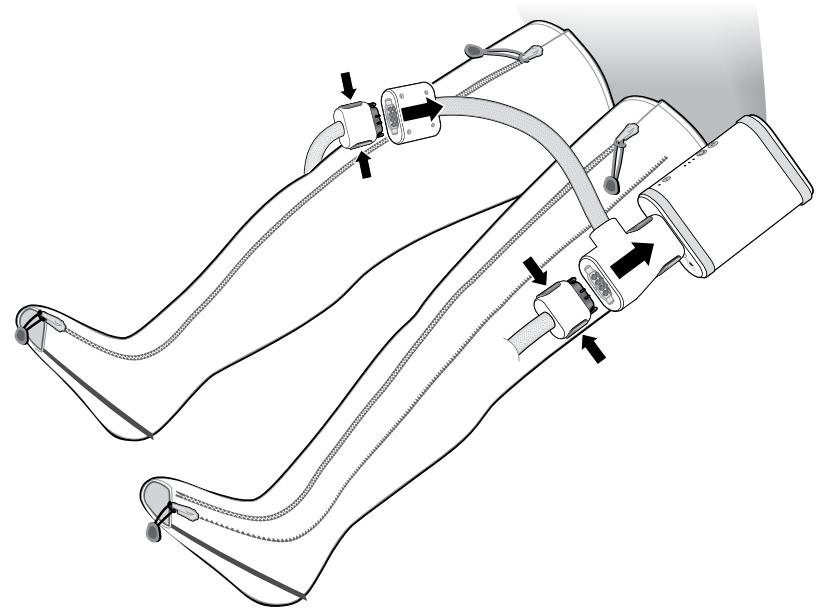
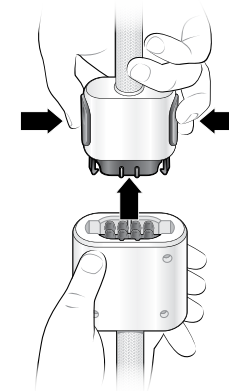

Figure 5.5.c. Removing the Connector from the Optional Connector Extension



5.6 Storing the Nimbl System

To store the Nimbl system, follow the steps below:

1. Unplug the power adapter cord from the controller unit and from the electrical outlet.
2. Store the garment by first folding the tubing for the garment. Avoid kinking the tubing. The garment can be folded. Do not stack anything on top of the garment.
3. Store the controller unit and garment in a cool, dry place. Keep them out of excessive heat or cold (see **Chapter 10** on page 44 for allowable storage temperatures). Store them away from children and pets.

5.7 Cleaning the Nimbl System

To clean the controller unit and/or garment, follow the steps below:



CAUTION: Read All Instructions Before Cleaning

- Do not submerge
- Do not disassemble
- Do not machine dry
- Do not iron
- Do not machine wash
- Do not dry clean
- Do not autoclave
- Do not steam sterilize

WARNING: Risk of Electric Shock

Unplug the power adapter cord from the electrical outlet prior to cleaning the controller unit. Allow the controller unit to dry completely prior to connecting the power adapter to the electrical outlet.

Cleaning the Controller Unit

The controller unit can be cleaned, as needed, using a damp cloth and mild household cleaner:

1. Unplug the power adapter from the electrical outlet.
2. Wipe all accessible surfaces including the power adapter.
3. After cleaning, allow the unit to dry completely prior to using.

Cleaning the Garment

1. A lint brush or roller may be used to remove particles on the inside of the garment.
2. The outside portion of the garment may be cleaned using a damp cloth and a mild detergent.
3. Allow garment and accessories to dry thoroughly prior to using.

5.8 Disinfecting the Nimbl System



CAUTION

Follow instructions and warnings as issued by manufacturer of any disinfecting product.

DisCide® ULTRA Spray Disinfectant has been demonstrated to effectively disinfect the Nimbl system. Use DisCide ULTRA Spray or similar disinfectant compliant with OSHA's Bloodborne Pathogen Standard (29 CFR 1910.1030) and/or registered with EPA. To disinfect the Nimbl system, including garments, controller or accessories between patient use, or if there are visible biological contaminants or visible stains, the following steps are recommended:

1. Clean any visible blood or body fluids from the surface of the garment.
2. Thoroughly wet surface with DisCide ULTRA Disinfecting Spray.
3. Allow surfaces to remain wet for one minute and then allow to air dry.

Troubleshooting and Specifications

If you experience a problem with the Nimbl system, refer to the information in **Table 1** (that begins below) for assistance and **Table 2** on page 35 for LED display information. If the information in these tables do not help solve the problem, contact Customer Care:

- **Text or Call:** 612.355.5100
- **Toll Free Phone:** 833.3TACTILE (833.382.2845)
- **Email:** customerservice@tactilemedical.com
- **Customer Care Hours:** 7 a.m. to 7 p.m. CT, Monday–Friday



CAUTION

The Nimbl system contains no serviceable parts. Do not attempt to perform any unauthorized maintenance or repairs.

Table 1: Troubleshooting

Problem	Recommended Solution
Controller unit does not function	Disconnect the power adapter from the controller unit and then reconnect. Ensure that the power adapter is fully inserted in both the power inlet on the controller unit and the wall outlet. Ensure the wall outlet is functioning. A green light will illuminate on the power adapter if the wall outlet and power adapter are functioning.
Issues with the Bluetooth® connection	Wireless and RF technology systems with a similar frequency that are used near the Nimbl system may impact the range and reliability of the Bluetooth® connection. If you experience issues with the Bluetooth® connection on the Nimbl system, try the following: <ol style="list-style-type: none"> 1. Decrease the distance between the controller and mobile device. 2. Remove any objects that are between the controller and mobile device. 3. Move the controller and mobile device away from other systems that may cause interference (i.e. Wi-Fi routers, Bluetooth® streaming devices, microwave ovens, baby monitors, and other mobile phones). 4. Please text or call Customer Care if you are unable to resolve the problem.

Table 1: Troubleshooting (continued)





Problem	Recommended Solution
The chambers do not fill with air	The controller unit detected the system’s pressure is too high (most likely due to kinked tubing). <ol style="list-style-type: none"> 1. Unplug the device. If able, disconnect the garment from the controller unit and then reconnect again. Plug in the device. Restart the treatment session by pressing the  button. 2. Ensure the garment tubing is not kinked in any way, as this is the most common reason for the problem. 3. Do not stand on garment during treatment. 4. To confirm proper functioning of the controller unit and garment, you may take the garment off and lay it flat on the floor, power up the device, and press the  button to begin a treatment session and confirm all chambers sequentially inflate. 5. Please text or call Customer Care for assistance if you are unable to resolve the problem.
Controller unit does not work, and the garment does not inflate	The controller unit was unable to produce or maintain pressure in any of the garment chambers. <ol style="list-style-type: none"> 1. Unplug the device. If able, disconnect the garment from the controller unit and then reconnect again. Plug in the device. Restart the treatment session by pressing the  button. 2. Please text or call Customer Care if you are unable to resolve the problem.
Controller unit does not function, and holds pressure in the garment	The controller unit was unable to release pressure from the system. <ol style="list-style-type: none"> 1. Unplug the device. If able, disconnect the garment from the controller unit and then reconnect again. Plug in the device. Restart the treatment session by pressing the  button. 2. Please text or call Customer Care if you are unable to resolve the problem.

Table 1: Troubleshooting (continued)





Problem	Recommended Solution
Controller unit does not function.	The controller unit detected an issue during self-test. <ol style="list-style-type: none"> 1. Unplug the device. Plug in the device. Restart the treatment session by pressing the  button. 2. Please text or call Customer Care if you are unable to resolve the problem.
Cannot change pressure setting.	Once you start a treatment, settings cannot be changed unless the treatment program has completed. To change pressure settings, unplug the device. Plug in the device. Then settings may be adjusted by pressing the  button.
The garment chambers do not fill with air.	<ol style="list-style-type: none"> 1. Verify the  button has been pressed. 2. Verify that the connectors are attached properly and that the hoses are not kinked. 3. Ensure that both upper and lower connector latches are engaged. 4. If the chambers still do not fill, unplug the machine, detach the connectors, and plug in the machine. 5. Press the  button to begin a treatment session. 6. Feel for air coming out of the controller unit, reconnect the hose.
Garment pressures are higher or lower than expected.	<ol style="list-style-type: none"> 1. Verify that the correct pressure has been selected. 2. Adjust the fit of the garment, ensuring no folds or kinks are in the fabric. 3. Check to be sure the latches are firmly in place and attached properly.

Table 1: Troubleshooting (continued)



Problem	Recommended Solution
Garment remains inflated.	It is normal for a small amount of air to remain in the chambers between inflations, giving the garment a puffy appearance. If the chambers remain fully inflated: <ol style="list-style-type: none"> 1. Press and hold the  button for at least three seconds to start the active exhaust process. 2. Ensure that the tubing is not kinked or pinched. 3. Disconnect the connectors and the chambers should deflate.
Controller unit runs longer than expected.	A treatment session will last approximately 60 minutes. Please text or call Customer Care if controller unit runs significantly longer than 60 minutes.
Zippers have broken or become disconnected from garment.	Text or call Customer Care for assistance.
Any button does not function.	<ol style="list-style-type: none"> 1. Unplug the device. Plug in the device. 2. Text or call Customer Care for instructions.
The controller unit makes an abnormal noise.	<ol style="list-style-type: none"> 1. Stop the treatment session by pressing the  button. 2. Verify the noise has stopped. 3. Restart the treatment by pressing the  button. 4. If the noise continues, stop the treatment by unplugging the device and text or call Customer Care.



Table 2: LED Reference Guide		
LED Pressure Setting Lights (white)		
If three LED lights on the side of the device are fully illuminated, that means your device is running as expected. For any other combination of lights, reference the information below to determine the issue and resolution.		
On: ● Off: ○ Slow Blinking: ● Fast Blinking: ★ Bluetooth®: 📶 (See Figure 6.1.a. Device Orientation for LED Lights)		
What do the lights mean?	What to do:	
● ● ●	High pressure treatment ready or running	
● ● ●	High pressure treatment exhausting garment	
○ ● ●	Medium pressure treatment ready or running	
○ ● ●	Medium pressure treatment exhausting garment	
○ ○ ●	Low pressure treatment ready or running	
○ ○ ●	Low pressure treatment exhausting garment	
○ ○ ★	Single chamber fill timeouts 5 times in a row	
○ ★ ○	Consecutive chamber fill timeouts 17 times or more	
○ ★ ★	Overpressure in 3 consecutive cycles	
★ ○ ○	Pressure sensor errors	
★ ○ ★	No pressure detected	
★ ★ ○	Exhaust timeouts at the end of a cycle	
★ ★ ★	Reduce 8 timeouts for at least 5 consecutive cycles	
	<ol style="list-style-type: none"> 1. Unplug the device. If able, disconnect the garment from the controller unit and then reconnect again. Plug in the device. Restart the treatment session by pressing the  button. 2. Ensure the garment tubing is not kinked in any way, as this is the most common reason for the problem. 3. Do not stand on garment during treatment. 4. To confirm proper functioning of the controller unit and garment, you may take the garment off and lay it flat on the floor, power up the device and press the  button to begin a treatment session and confirm all chambers sequentially inflate. 5. Please text or call Customer Care for assistance if you are unable to resolve the problem. 	

Table 2: LED Reference Guide (continued)		
LED Bluetooth® Light (blue)		
What do the lights mean?	What to do:	
No LED	No bonded device settings	
Solid Blue	Bonded device settings exist	
Fast flashing blue	Pairing process initiated (60 seconds max)	
Slow flashing blue	Paired and communicating (Transmit/Receive underway) to bonded device	
Rechargeable Battery (optional accessory)		
What do the lights mean?	What to do:	
★ ★ ★ ★	Battery power too low	Plug the Nimbl power supply into the wall and into the port on the battery to charge the battery. The LEDs on the battery unit will stop flashing when fully charged.

*Tactile Medical Customer Care can be reached via text or phone at 612.355.5100, or toll free via phone at 833.3TACTILE (833.382.2845), 7 a.m. to 7 p.m. CT, Monday–Friday.

Figure 6.1.a. Device Orientation for LED Lights

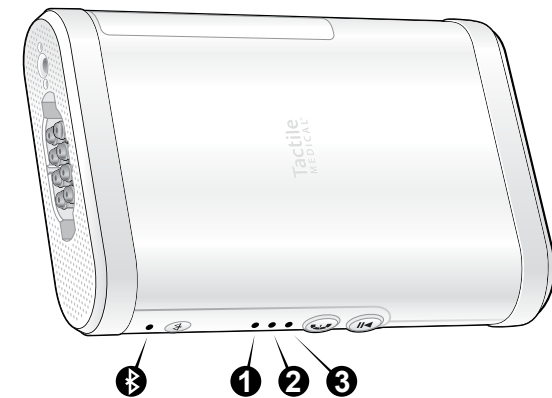

Warranty

7.1 Limited Warranty and Service for Home Use

Tactile Medical provides a warranty for the Nimbl system. The Nimbl Controller unit, garment, and garment accessories are warranted to be free from defects in material and workmanship for a period of one (1) year from the date of purchase. Tactile Medical's sole obligation in the event of a breach of this warranty is expressly limited to the replacement of defective parts. Replacement parts may be new or reconditioned parts as solely determined by Tactile Medical. No representation or other affirmation of fact set forth in this agreement, including but not limited to statements regarding suitability for use or performance of the Nimbl system, shall be deemed to be a warranty or representation by Tactile Medical for any purpose, nor give rise to any liability or obligation of Tactile Medical. EXCEPT FOR THE FOREGOING, TACTILE MEDICAL MAKES NO OTHER WARRANTY. THE WARRANTIES SET FORTH HERE ARE IN LIEU OF ALL OTHER WARRANTIES, EXPRESSED OR IMPLIED, WHICH ARE HEREBY DISCLAIMED AND EXCLUDED BY THE MANUFACTURER, INCLUDING WITHOUT LIMITATION ANY WARRANTY OF MERCHANTABILITY OR FITNESS FOR A PARTICULAR PURPOSE OR USE AND ALL OBLIGATIONS OR LIABILITIES ON THE PART OF TACTILE MEDICAL FOR DAMAGES ARISING OUT OF OR IN CONNECTION WITH THE USE, REPLACEMENT OR PERFORMANCE OF THE NIMBL SYSTEM. IN NO EVENT SHALL TACTILE MEDICAL BE LIABLE FOR ANY SPECIAL, DIRECT, INDIRECT OR CONSEQUENTIAL DAMAGES. Some states, provinces or countries do not allow exclusion or limitation of incidental or consequential damages, so the above limitation or exclusion may not apply.

This warranty is available only to the original user and is not transferable. Alterations to the product not conducted by Tactile Medical shall void these warranties. These warranties do not cover failures due to improper or negligent use of the product.

These warranties provide specific legal rights; there may be other available rights, which may vary by state, province or country.

7.2 Limited Warranty and Service for Facility Use

Contact Tactile Medical for information regarding the service agreements available to facilities.

7.3 Return Policy

Returns are accepted for unopened products within 60 days of receipt.

7.4 Equipment Lifetime

When used and maintained as instructed, the average expected controller unit lifetime is five years.

Tactile Medical reserves the right to modify product specifications as part of its continuing program of product development and quality improvement.

Cybersecurity Introduction

This section contains information related to the cybersecurity and privacy controls that are part of the Kylee application to help ensure the safe and effective use of the Nimbl system.

Tactile Medical has implemented the following secure design practices for all products:

- Risk identification and mitigation
- Design input requirements engineering
- Secure design controls
- Traceability
- Secure implementation
- Verification and validation

These practices are meant to ensure security considerations for all design solutions in development, and to provide a method to quickly address newly discovered security vulnerabilities and threats to products already placed on the market.

Tactile Medical identifies security risks and tests the corresponding mitigations throughout the development process. External third-party penetration testing, vulnerability assessments, and secure code analysis and reviews are also standard practice during the development and final production readiness phases.

The following information addresses the security principles identified in the Food and Drug Administration (FDA) guidance: Cybersecurity in Medical Devices: Quality System Considerations and Content of Premarket Submissions (September 2023), as well as best practices in information security and design.

8.1 Security of Data

Tactile Medical followed a secure design life cycle approach in ensuring the confidentiality, integrity, and availability (CIA) of the information assets within the Nimbl system and Kylee application.

8.2 Confidentiality

Encryption is utilized to ensure data confidentiality. The Advanced Encryption Standard (AES) protects all patient data while it is in transit or storage in the Nimbl controller and Kylee application.

The Nimbl system utilizes a Bluetooth® connection to pair and transmit data from the Nimbl controller to the Kylee mobile application. The system only supports pairing over Bluetooth® with the Kylee app and does not support connectivity or data exchange with any other application or system.

Pairing is enabled using the Bluetooth® Just Works method, which requires sharing specific preprogrammed unencrypted information while the connection is established. This unencrypted data is used to confirm the connection with a trusted device and is only present during initial pairing with a device; it is not present or exchanged after the device has been paired.

Protected Health Information (PHI) is not transmitted during Bluetooth® pairing or data syncing and transmission. Additionally, the Kylee app allows pairing and communication with one Nimbl device, and Nimbl only allows one paired mobile device to the controller, which creates a trusted singular connection. After pairing and during data transmission over Bluetooth®, the link utilizes AES encryption at the application layer to protect the transmission of treatment data.

Application layer encryption is implemented as a defense-in-depth strategy to ensure the confidentiality of information even if future vulnerabilities and limitations are discovered in the Bluetooth® protocols. The Kylee app handles Protected Health Information (PHI), but it is considered low risk since the PHI does not include health insurance, billing or prescription information. Extra precautions have been taken to ensure that the patient data is retained in the Kylee app only during the data transmission process and is ultimately stored with the Tactile Medical network.

Device usage, error, and program data are encrypted on the Nimbl device with the ChaCha20-Poly1305 method before being transmitted over the AES encrypted Bluetooth® connection to the Kylee mobile app. During transmission of patient data from the Kylee app to the Tactile Medical network, the data is protected by a Transport Layer Security (TLS) network connection and utilizes the AES-256 method during transfer and rest. If the Kylee app cannot complete the transmission to the Tactile Medical network, the Kylee app will try to transfer the data to the Tactile Medical network a maximum of five times during a session. If unsuccessful, the app will not retain the patient data and will retry the transmission during a future session.

8.3 Availability

The Kylee app was designed to be highly successful with patient data transmission to the Tactile Medical network when the device has reliable Internet connectivity. Because patient data handled by the Kylee app is not needed or reviewed by users in real time, the Kylee app will attempt to transfer the data to the Tactile Medical network until successful. This mitigates against patient data loss due to reductions or outages in the cellular network, Wi-Fi network, or the Tactile Medical network.

8.4 Authentication and Authorization

The Kylee app utilizes authentication to access all application features and requires positive matching of user information to complete pairing to the Nimbl device. To prevent unauthorized access to the Kylee app, the user is advised to enable either passcode or biometrics-based authentication on their mobile phone or tablet. The Kylee app uses AES encryption to protect patient credentials when entered in the application and it does not prompt any user passwords.

8.5 Accountability

Each Nimbl device has a unique serial number and patient credentials. These items are used to uniquely identify each Nimbl device when it is used to connect to the Tactile Medical network. Also, each Kylee app installation has a secure ID that is used to uniquely identify the app when it interacts with the Tactile Medical network.

8.6 Summary

The secure design of the Nimbl system and Kylee application began with development of a preliminary risk analysis and threat model that considered safety and cybersecurity risks. The identified risks were then used to generate the security design input requirements that continue to be updated as new vulnerabilities and threats are discovered in technologies utilized in and interfaced by the Kylee application. The development of requirements has led to a strong security architecture that has been tested and reviewed, both internally and externally. Design controls like strong mobile application security, encryption for data storage, and secure communications were implemented to reduce security risks. The security design controls have effectively reduced security and patient safety risks to the lowest rate.

FCC Compliance

This device contains FCC ID: QOQ-GM220P. This device complies with Part 15 of the FCC Rules. Operation is subject to the following two conditions: (1) this device may not cause harmful interference, and (2) this device must accept any interference received, including interference that may cause undesired operation. This equipment has been tested and found to comply with the limits for a Class B digital device, pursuant to part 15 of the FCC Rules. These limits are designed to provide reasonable protection against harmful interference in a residential installation. This equipment generates, uses, and can radiate radio frequency energy, and if not installed and used in accordance with the instructions, may cause harmful interference to radio communications. However, there is no guarantee that interference will not occur in a particular installation. If this equipment does cause harmful interference to radio or television reception, which can be determined by turning the equipment off and on, the user is encouraged to try to correct the interference by one or more of the following measures:

- Reorient or relocate the receiving antenna
- Increase the separation between the equipment and receiver
- Connect the equipment into an outlet on a circuit different from that to which the receiver is connected

NOTE: "Harmful Interference" is defined in 47 CFR by the FCC as follows: Interference which endangers the functioning of a radionavigation service or of other safety services or seriously degrades, obstructs or repeatedly interrupts a radio communication service operating in accordance with the (ITU) Radio Regulations.

Technical Information

10.1 Technical Information

The Nimbl system has the following characteristics:

Table 3: Nimbl System – Technical Information	
Model Number	PD08-N1
Power Adapter Input	100~240 VAC
Voltage/Frequency	50~60 Hz
Power Adapter Input Current	0.9-0.45 A
Device Input Voltage	12 VDC Nominal
Device Input Current	3.0 A Maximum
Pressure Settings	HIGH, MED and LOW
Controller Unit Size	2.0" x 5.7" x 8.3" (51 mm x 145 mm x 211 mm)
Controller Unit Weight	1.75 lbs. (0.8 kgs)
Fabrics	Nylon and polyester. Not made with natural rubber latex.
Therapy Programs	1
Chambers	8
Mode of Operation	Continuous
Calibration	Recalibration not required
Electromagnetic Interference (EMI) Electromagnetic Compatibility (EMC)	The Nimbl system was designed to minimize the effects of external EMI upon the device and to minimize the effect upon the environment from the device. The device conforms to the EMC standards. See Tables 5, 6, and 7 beginning on pgs. 45, 45, and 46, respectively.
Operating Atmospheric Pressure	700 to 1060 hPa

Device Transport and Storage Temperature Limits	Device Operating Temperature Limits (15°C to 35°C)	Device Transport and Storage Humidity Limits	Device Operating Humidity Limits
			

Table 4: Nimbl System – Classification Information	
U.S. FDA Medical Device	Class II per 21 CFR 870.5800
Protection Against Electric Shock Hazard	Class I per UL/EN/IEC 60601-1
Protection Against Fluid Ingress	IP22
Applied Part	BF

Table 5: Nimbl System – Conformance Information	
Quality Assurance	FDA 21 CFR 820 QSR ISO 13485
Safety	IEC 60601-1
Electromagnetic Compatibility (EMC)	IEC 60601-1-2
Waste Electrical & Electronic Equipment (WEEE)	Directive 2002/96/EC
Restriction of Hazardous Substances	Directive 2002/95/EC

Table 6: Guidance and Manufacturer’s Declaration – Electromagnetic Emissions		
The Nimbl system is intended for use in the electromagnetic environment specified below. The customer or the user of the Nimbl system should assure that it is used in such an environment.		
Emissions Test	Compliance	Electromagnetic Environment – Guidance
RF Emissions CISPR 11	Group 1	The Nimbl system uses RF energy only for its internal function. Therefore, its RF emissions are very low and are not likely to cause interference to nearby electronic equipment.
RF Emissions CISPR 11	Class B	The Nimbl system is suitable for use in all establishments, including domestic establishments and those connected to the public low voltage power adapter network that supplies buildings used for domestic purposes.
Harmonic Emissions IEC 61000-3-2	Not applicable	
Voltage Fluctuations/ Flicker Emissions IEC 61000-3-3	Complies	

Table 7: Guidance and Manufacturer’s Declaration – Electromagnetic Immunity			
The Nimbl system is intended for use in the electromagnetic environment specified below. The customer or the user of the Nimbl should assure that it is used in such an environment.			
Immunity Test	IEC 60601 Test Level	Compliance Level	Electromagnetic Environment – Guidance
Electrostatic Discharge (ESD) IEC 61000-4-2	± 6 kV contact	± 8 kV contact	Floors should be wood, concrete or ceramic tile. If floors are covered in synthetic material, the relative humidity should be at least 30%.
	± 8 kV air	+/-2 kV, +/-4 kV, +/-8 kV, +/-15 kV air	
Electrical Fast Transient/Burst IEC 61000-4-4	± 2 kV for power supply lines	± 2 kV for power supply lines	Mains power quality should be that of a typical commercial or hospital environment.
	± 100 kHz repetition	± 100 kHz repetition	
Surge IEC 61000-4-5	± -5 kV	± -5 kV	
	± -1 kV line to line	± -1 kV line to line	
	± -5 kV	± -5 kV	
	± -1 kV	± -1 kV	
	± -2 kV line to earth	± -2 kV line to earth	
Voltage Dips, Short Interruptions and Voltage Variations on Power Adapter Lines IEC 61000-4-11	Voltage dips 0% UT; 0,5 cycle	Voltage dips 0% UT; 0,5 cycle	Mains power quality should be that of a typical commercial or hospital environment. If the user of the Nimbl system requires continued operation during power mains interruptions, it is recommended that the device be powered from an uninterruptible power adapter.
	At 0°, 45°, 90°, 135°, 180°, 225°, 270° and 315° 0% UT; 1 cycle and 70% UT; 25 periods at 50 Hz, 30 periods at 60 Hz	At 0°, 45°, 90°, 135°, 180°, 225°, 270° and 315° 0% UT; 1 cycle and 70% UT; 25 periods at 50 Hz, 30 periods at 60 Hz	
	Single phase: at 0°	Single phase: at 0°	
	Voltage Interruptions 0% UT; 250 periods at 50 Hz, 300 periods at 60 Hz	Voltage Interruptions 0% UT; 250 periods at 50 Hz, 300 periods at 60 Hz	

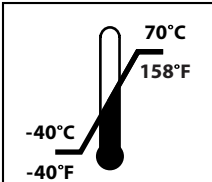
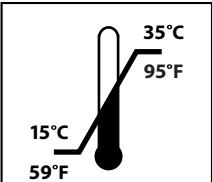
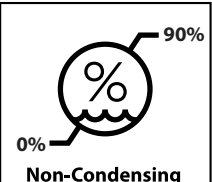
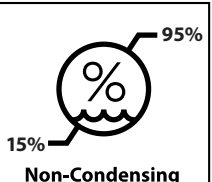
NOTE: U_r is the a.c. mains voltage prior to application of the test level.

Table 7: Guidance and Manufacturer’s Declaration – Electromagnetic Immunity (continued)

The Nimbl system is intended for use in the electromagnetic environment specified below. The customer or the user of the Nimbl should assure that it is used in such an environment.

Immunity Test	IEC 60601 Test Level	Compliance Level	Electromagnetic Environment – Guidance
Power Frequency (50/60 Hz) Magnetic Field IEC 61000-4-8	3 A/m	3 A/m	Power frequency magnetic fields should be at levels characteristic of a typical location in a typical commercial or hospital environment.
Conducted RF IEC 61000-4-6	3 Vrms 150 kHz to 80 MHz 6 Vrms in ISM and amateur radio bands between 0.15 MHz and 80 MHz 80% AM at 1 kHz	3 Vrms .15 kHz to 80 MHz 6 Vrms in ISM and amateur radio bands between 0.15 MHz and 80 MHz 80% AM at 1 kHz	
Radiated RF IEC 61000-4-3	10 V/m 80 MHz to 2,7 GHz 80 AM at 1 kHz	10 V/m 80 MHz to 2,7 GHz 80 AM at 1 kHz	

NOTE 1: At 80 MHz and 800 MHz, the higher frequency range applies.

NOTE 2: These guidelines may not apply in all situations. Electromagnetic propagation is affected by absorption and reflection from structures, objects and people.

* Field strengths from fixed transmitters, such as base stations for radio (cellular/cordless) telephones and land mobile radios, amateur radio, AM and FM radio broadcast, and TV broadcast cannot be predicted theoretically with accuracy. To assess the electromagnetic environment due to fixed RF transmitters, an electromagnetic site survey should be considered. If the measured field strength in the location in which the Nimbl system is used exceeds the applicable RF compliance level above, the Nimbl system should be observed to verify normal operation. If abnormal performance is observed additional measures may be necessary, such as reorienting or relocating the Nimbl system.

Table 8: Wireless Technology

The Nimbl Bluetooth® controllers use Bluetooth® Low Energy (BLE) 4.0+ that supports authenticated pairing with data signing which complies to IEE 802.15.1 and supports AES-CMAC encryption (FIPS-compliant, AES-128 via RFC 4493) during communications.

Technology Used	Bluetooth®
Connection Types	SPP, iAP2, GATT
Frequency	2400 to 2483.5 MHz
Max RF Power Output	+8.2 dBm
Operating Range	33 ft (10 m)

10.2 Device Labels





The device labels are found on the back and bottom of your device. To read the labels, place the device facing away from you at eye level at a distance that maximizes character clarity — generally 20 inches (50 cm) to 40 inches (100 cm) with an illumination of 500 lx minimum.

Call Tactile Medical Customer Care if label reading issues remain:

- **Text or Call:** 612.355.5100
- **Toll Free Phone:** 833.3TACTILE (833.382.2845)
- **Email:** customerservice@tactilemedical.com
- **Customer Care Hours:** 7 a.m. to 7 p.m. CT, Monday–Friday

NOTE:

- *Device labels are not to scale.*
- *Device labels’ depiction may be different than that on your device.*
- *See page 2 for symbol definitions.*

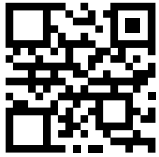
Tactile MEDICAL® MEDICAL ELECTRICAL EQUIPMENT AND DEVICES 3701 WAZATA BLVD, SUITE 300 MINNEAPOLIS, MN 55416 USA 833.382.2845 (833.3TACTILE) tactilemedical.com	REF NIMBL™ MODEL: PD08-N1 (01)00816305024678 (21)423-123456	 IP22  15°C / 59°F to 35°C / 95°F  TUV SUD FCC ID: Q00-GM220P	  703400-001 Rev F
	SN 423-123456 Rx Only RATED: 12VDC @ 3A MAX. NO SERVICEABLE PARTS MADE IN USA		

*Symbols, QR codes and numbers are only placeholders

For Additional Questions

If you have any questions that are not covered by this User Guide, our team is here to help. Please contact our Customer Care Team using one of the following options:

- **Text or Call:** 612.355.5100
- **Toll Free Phone:** 833.3TACTILE (833.382.2845)
- **Email:** customerservice@tactilemedical.com
- **Fax:** Toll free: 866.435.3949
- **Mail:** Tactile Medical, 3701 Wayzata Blvd, Suite 300, Minneapolis, MN 55416 USA
- **Customer Care Hours:** 7 a.m. to 7 p.m. CT, Monday–Friday

Tactile Medical

3701 Wayzata Blvd, Suite 300
Minneapolis, MN 55416 USA

tactilemedical.com

Customer Care

Text or Call: 612.355.5100

Toll Free Phone: 833.3TACTILE (833.382.2845)

Fax: 612.355.5101 / Toll Free Fax: 866.435.3949

Email: customerservice@tactilemedical.com

Hours: 7 a.m. to 7 p.m. CT, Monday–Friday

Tactile
MEDICAL®
HEALING RIGHT AT HOME

Tactile Medical and Kylee are registered trademarks and Nimbl and Healing Right at Home are trademarks of Tactile Medical. DisCid is a registered trademark of Palmero Health Care Corporation. The Bluetooth® word, mark and logos are registered trademarks owned by Bluetooth SIG, Inc. and any use of such trademarks by Tactile Medical is under license. No part of the contents of this guide may be reproduced or transmitted in any way, form, or by any means without the written permission of Tactile Medical.

©2025 Tactile Medical. All rights reserved. 703935-001 Rev C 1/2025